

LA Water Reuse Chapter Meeting



City of Glendale  
Glendale Water & Power

# »»» 2025 Recycled Water Master Plan Overview

February 11, 2025



# Arcadis at a glance



### OUR MISSION

Leading **global natural and built asset design & consultancy** firm working in partnership with our clients to deliver **exceptional and sustainable outcomes** through the application of design, consultancy, engineering, project and management services

### ENGINEERING NEWS RECORD 2023 GLOBAL SOURCEBOOK RANKINGS

#4

Water Supply

#1

Treatment and Desalination

#8

Dams and Reservoirs

#5

Transmission Lines and Aqueducts

### KEY STATISTICS

Founded in 1888

4+

gross revenue

BILLION

36

people worldwide

THOUSAND

200

net revenue in Water US

MILLION

1.1

people in Water US

THOUSAND

### BUSINESS AREAS

Resilience – Water/Environment



Mobility – Transportation



Places - Buildings





# Arcadis California Water Presence



**Water/Wastewater Supply & Treatment**  
Provide safe water and protect the environment



**Water Resiliency**  
Deliver supply planning, drought resilience, and local water source solutions



**Conveyance**  
Model/Move water/wastewater reliably and efficiently

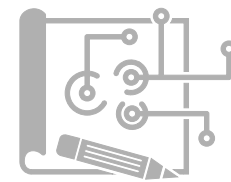

**Program Management/Owner's Agent**  
Provide holistic support for clients' complex projects

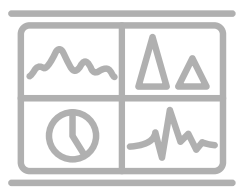

**Asset Management**  
Meet the service and performance expectations of customers, stakeholders, and regulators



**Construction Management**  
Oversee construction to monitor and report on contract compliance



# GWP Water and Recycled Water Master Plan Overview

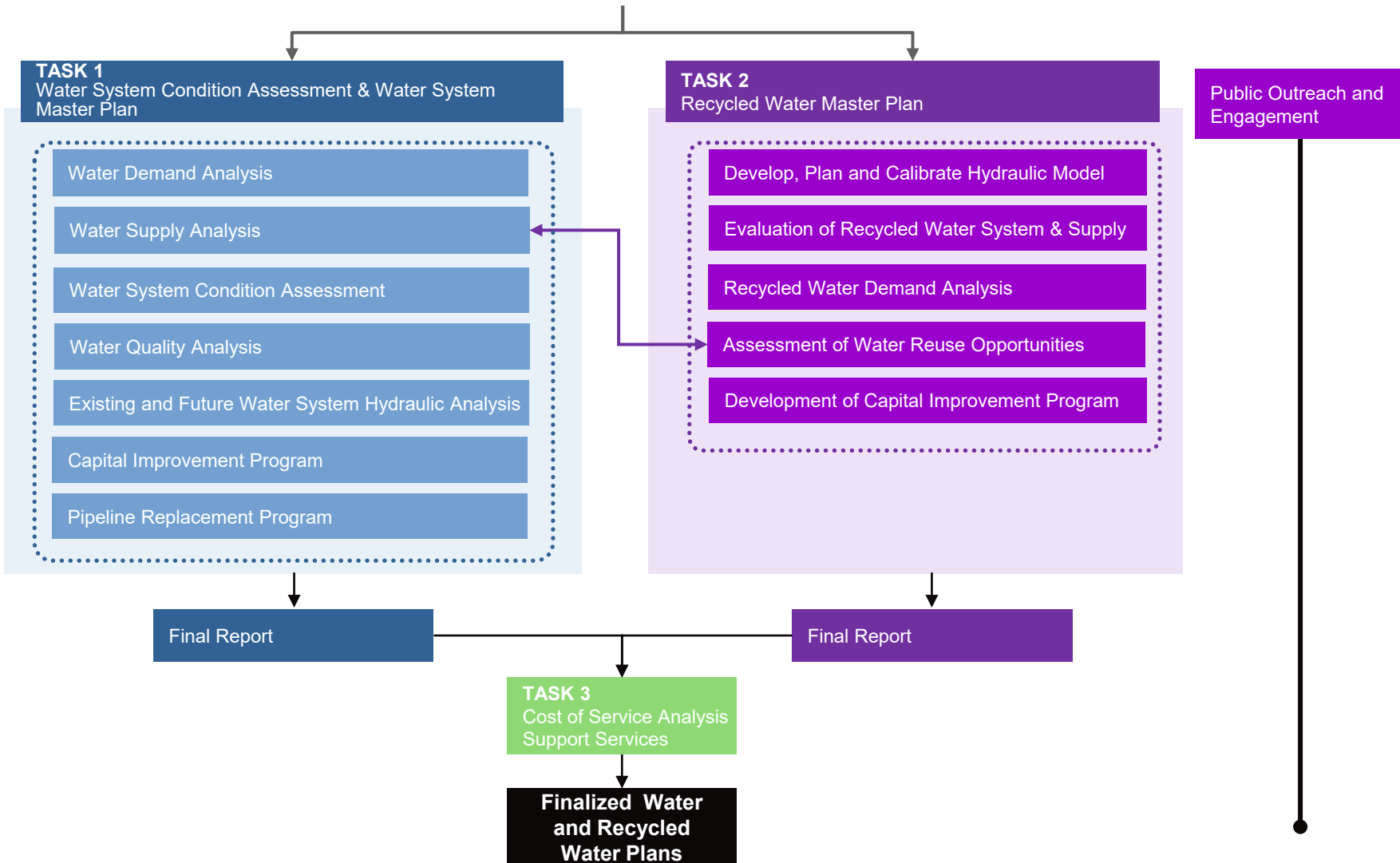

**K&A**  
KATZ & ASSOCIATES  
A SOUTHWEST STRATEGIES COMPANY

**K&A**  
KATHERINE PADILLA & ASSOCIATES, INC.

COMMUNITY OUTREACH

RECYCLED WATER MODELING & ASSESMENT OF REUSE OPPORTUNITIES

**HDR**

# Increasing Awareness and Gaining Acceptance



Strategic Communications & Stakeholder Research



Informational Materials



Outreach Sessions



Meetings & Events



Visual Communication



Promoting the Project



# Reuse Assessment

To Diversify and Secure Future for GWP's Potable and Recycled Supplies

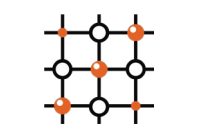

ALTERNATIVES IDENTIFICATION

Identify All Potential & Conceptual Potable and Recycled Supplies

Rank Future Potential Supplies through MCDA to Justify Best Supplies for GWP's Customers



MCDA

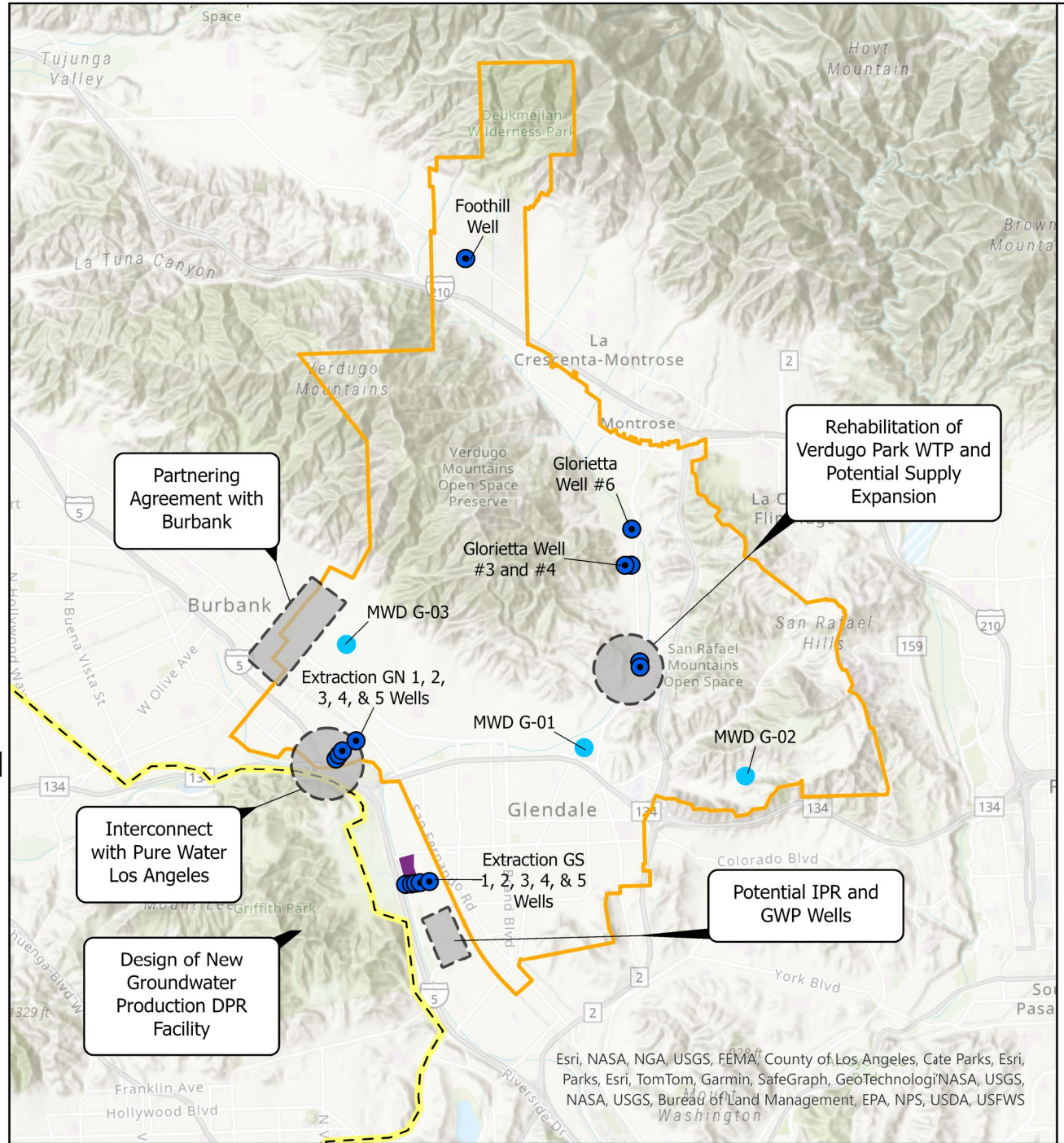

**LEGEND**

- City of Glendale Service Boundary
- LAGWRP
- MWD Connections
- Groundwater Production Wells
- Potential LADWP Los Angeles Pure Water Alignment
- New Potential Projects

0 0.5 1 2 3 4 Miles

N

Esri, NASA, NGA, USGS, FEMA, County of Los Angeles, Cate Parks, Esri, Parks, Esri, TomTom, Garmin, SafeGraph, GeoTechnology, NASA, USGS, NASA, USGS, Bureau of Land Management, EPA, NPS, USDA, USFWS

# »»» Thank You for Your Time

*Questions*

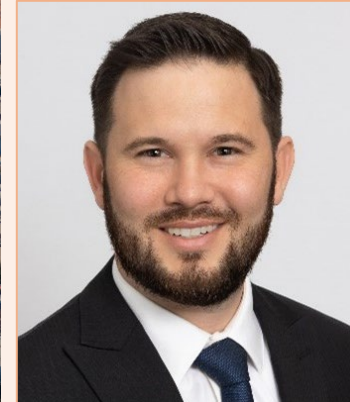

**Ryan Hejka, PE**  
*SoCal Planning Lead*

*Email:*

[ryan.hejka@arcadis.com](mailto:ryan.hejka@arcadis.com)

*Phone:*

(626) 342 -1191



# Overview of Upcoming LADWP DPR Pilot

**CDM  
Smith**

**LA  
DWP**



# LADWP's Path to Reuse

## Non-Potable Reuse



- Irrigation
- Industrial Uses
- Environmental

## Indirect Potable Reuse



- Terminal Island
- Donald C. Tillman
- Pure Water LA

## Direct Potable Reuse



- Pure Water LA
- Headworks DPR

# LADWP's Path to Reuse

## Non-Potable Reuse

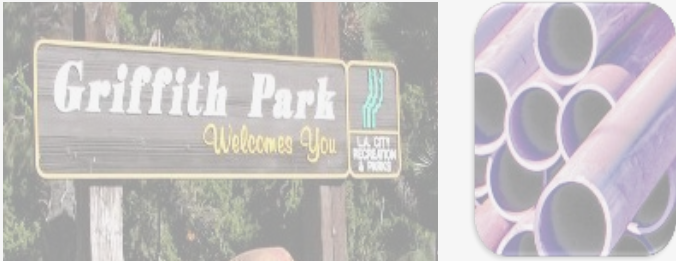

- Irrigation
- Industrial Uses
- Environmental

## Indirect Potable Reuse

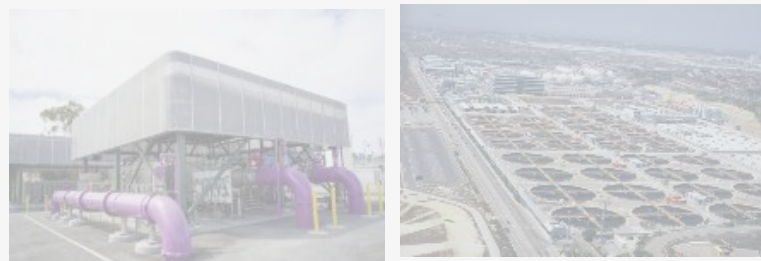

- Terminal Island
- Donald C. Tillman
- Pure Water LA

## Direct Potable Reuse



- Pure Water LA
- Headworks DPR ←

# LADWP Plans 1 MGD DPR Demonstration Facility



# DPR Demonstration Facility Project Phases

## Phase 1 – Demonstration Facility (1 MGD)

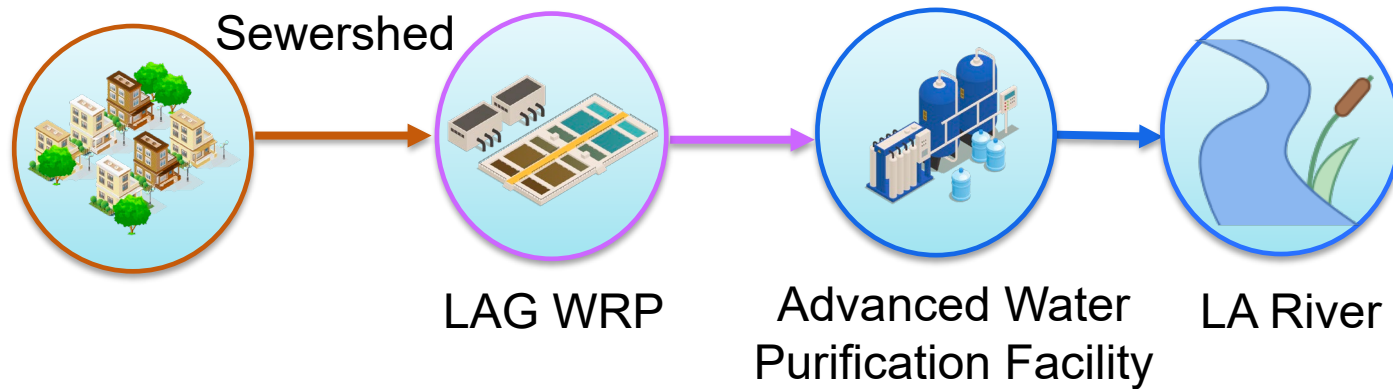

## Phase 2 – Initial DPR Operation (1 MGD)

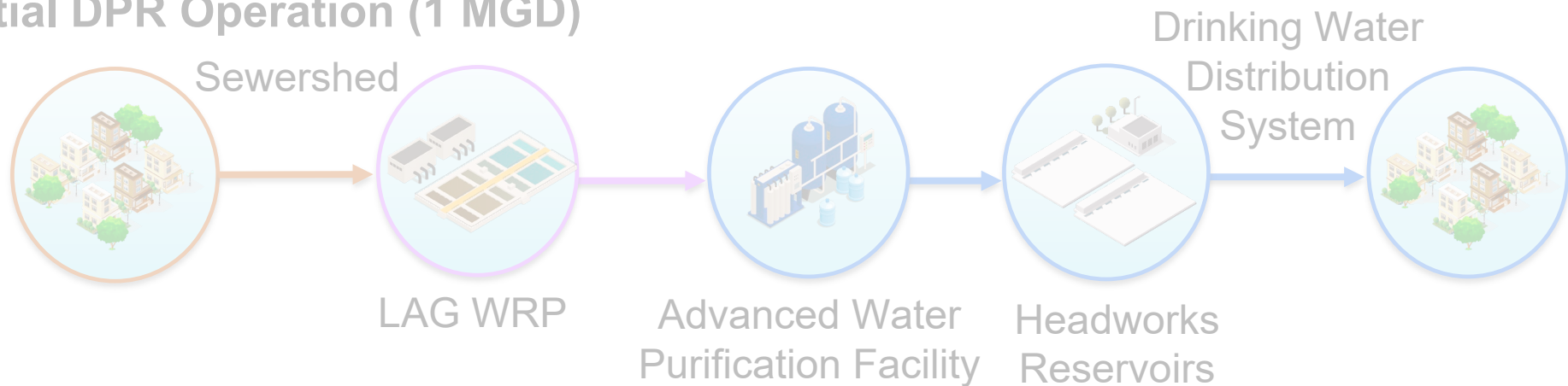

# Headworks DPR Project Schedule

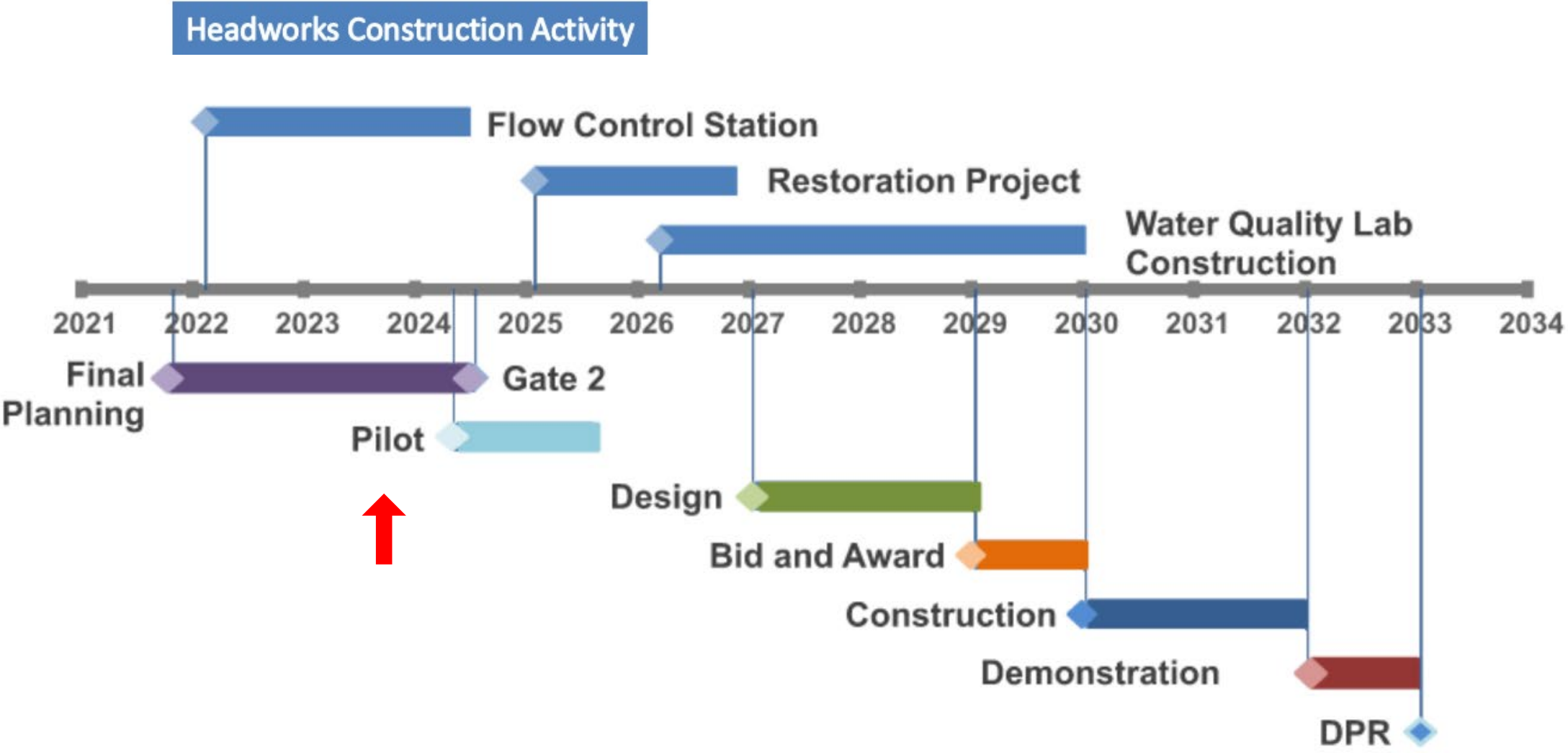



# Goals of Pilot Testing

- Collect data to comply with DPR regulations & engage regulators
- Optimize design of demo and full-scale facilities
- Evaluate process trains for addressing chemical spikes
- Evaluate direct monitoring of viruses for achieving LRVs
- Demonstrate integrity monitoring for critical control points

# Pilot Plant Location

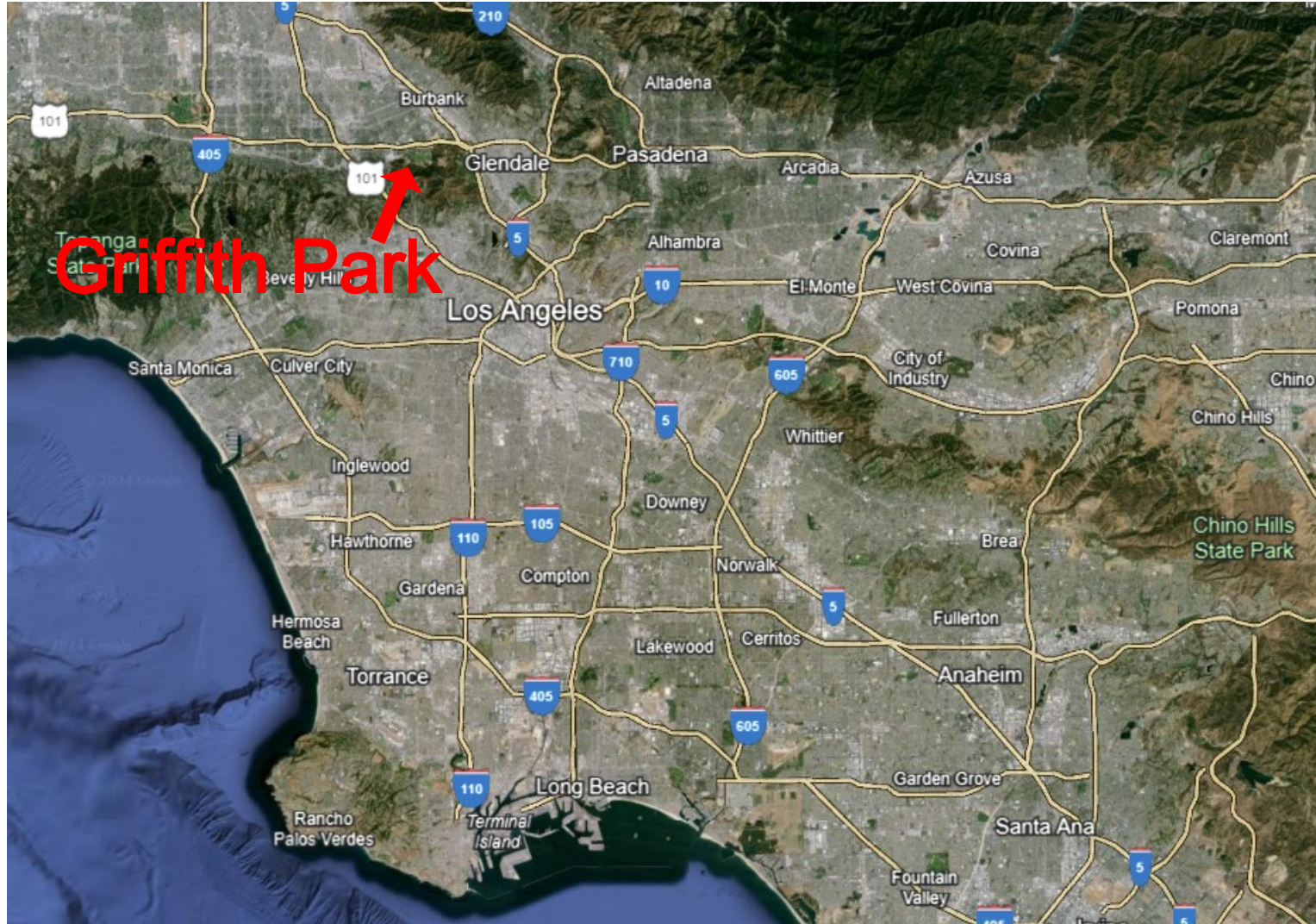

# Pilot Plant Location



★ – DPR Pilot (approximate location)



# Process Flow for Pilot

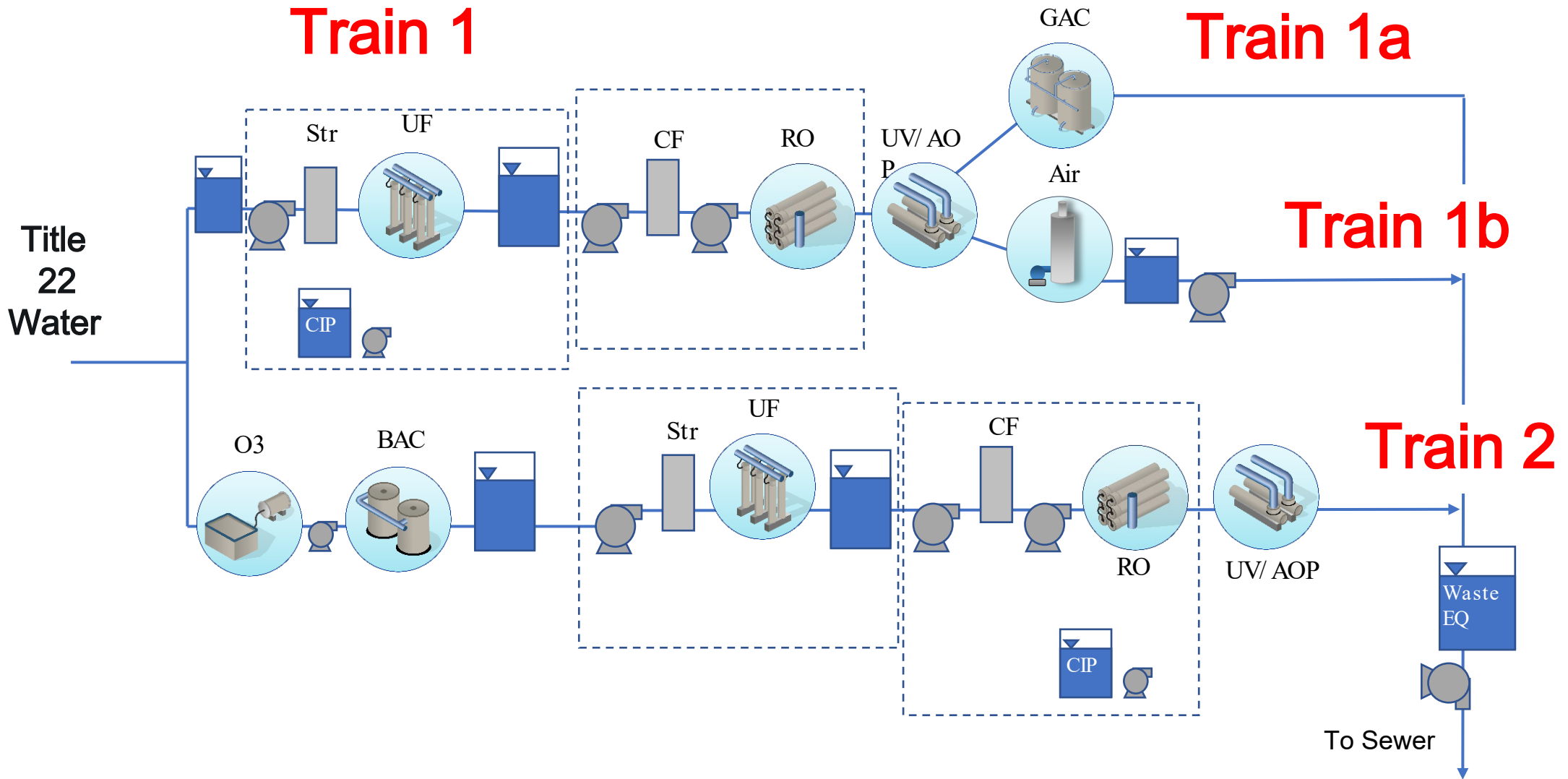



# Process Flow for Pilot

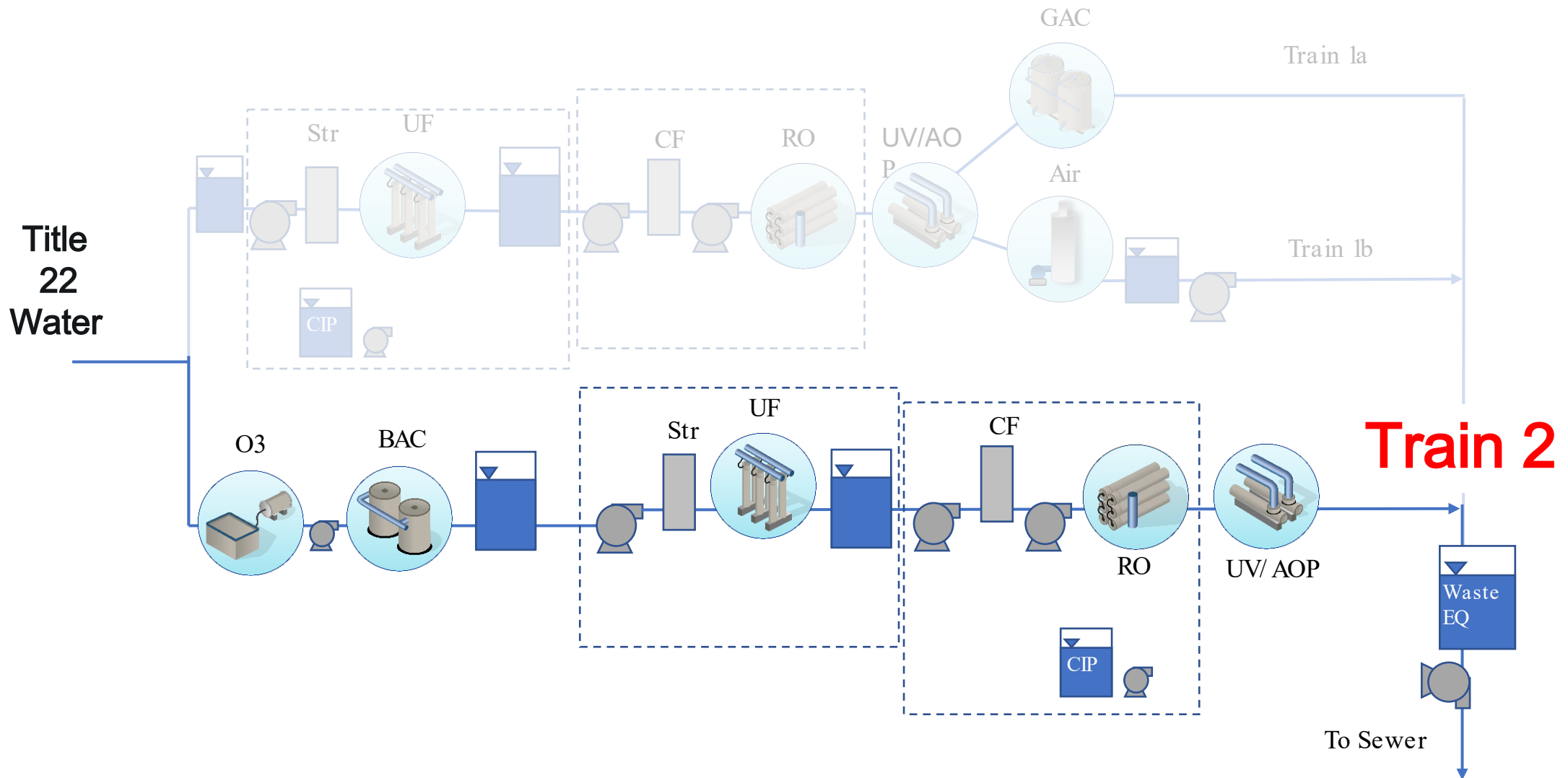

# Process Flow for Pilot

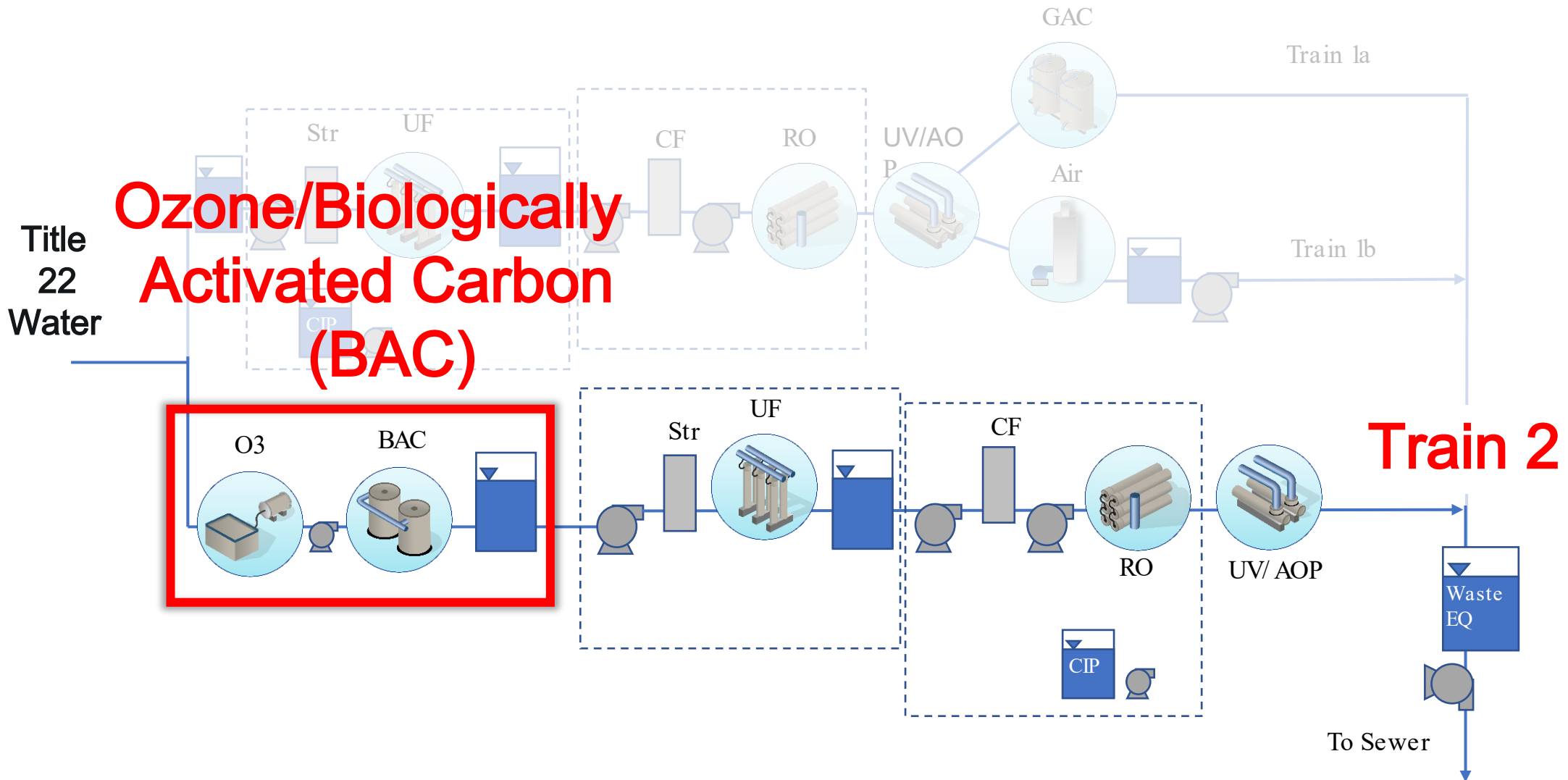

# Process Flow for Pilot

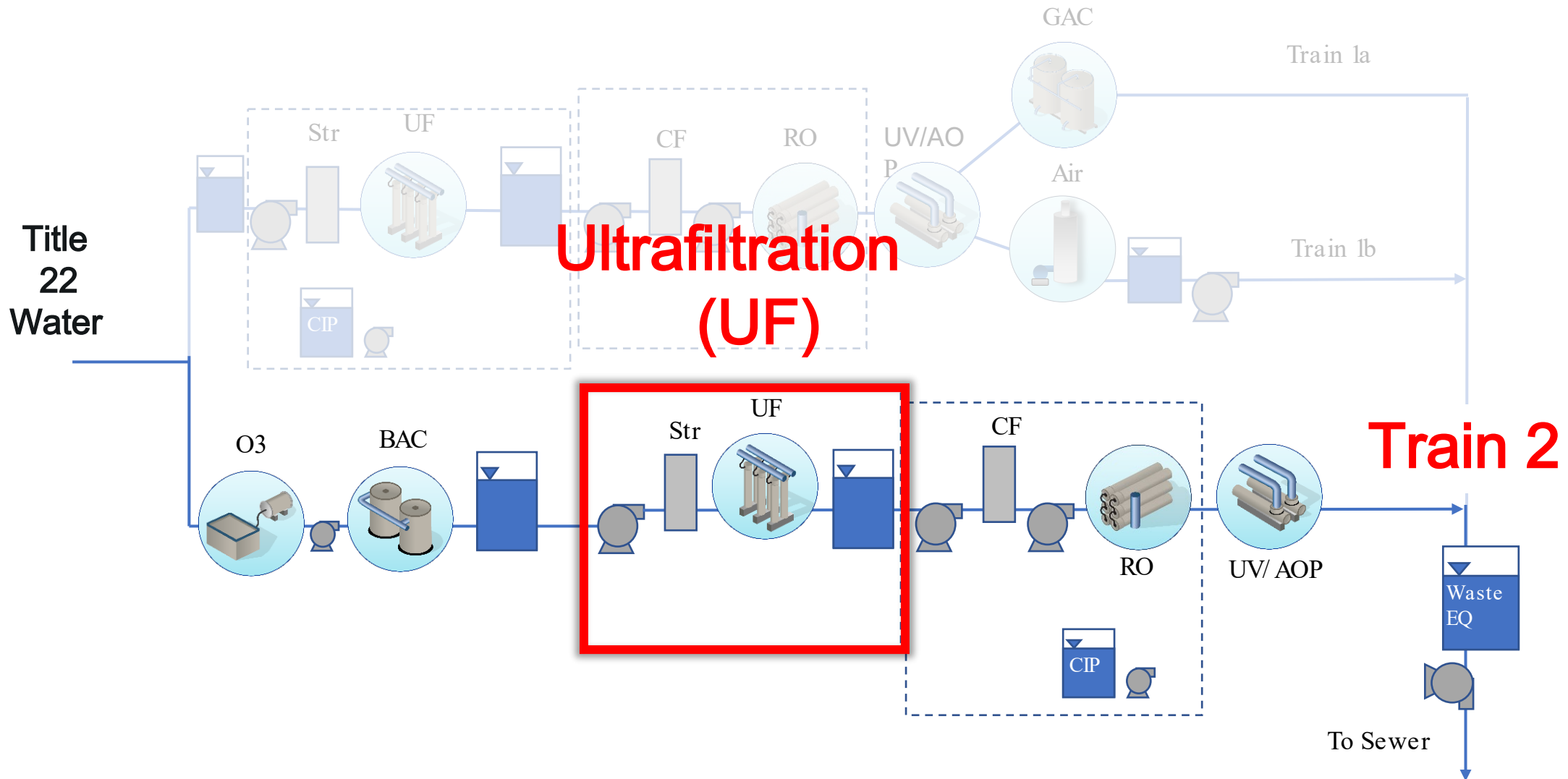

# Process Flow for Pilot

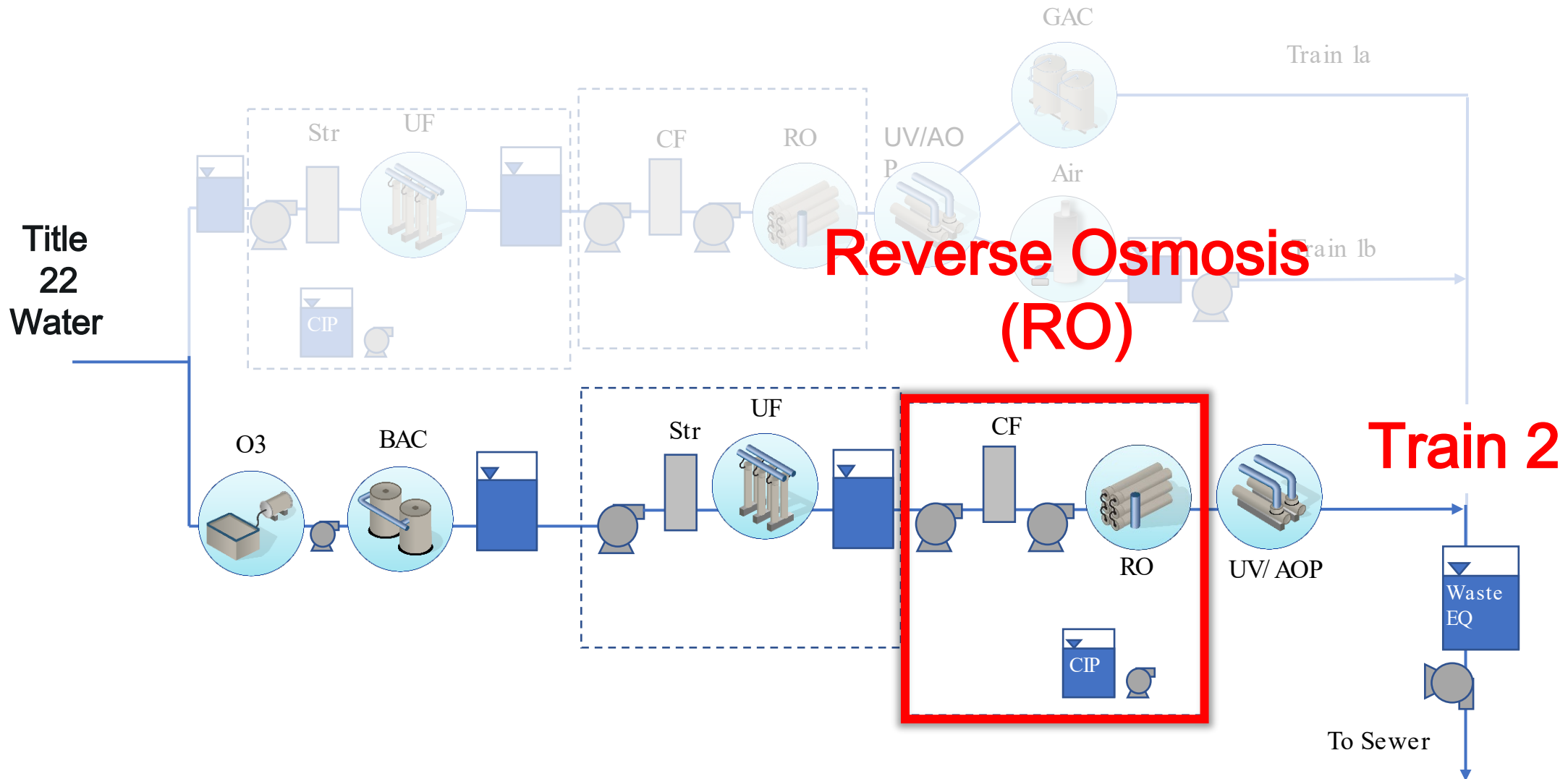

# Process Flow for Pilot

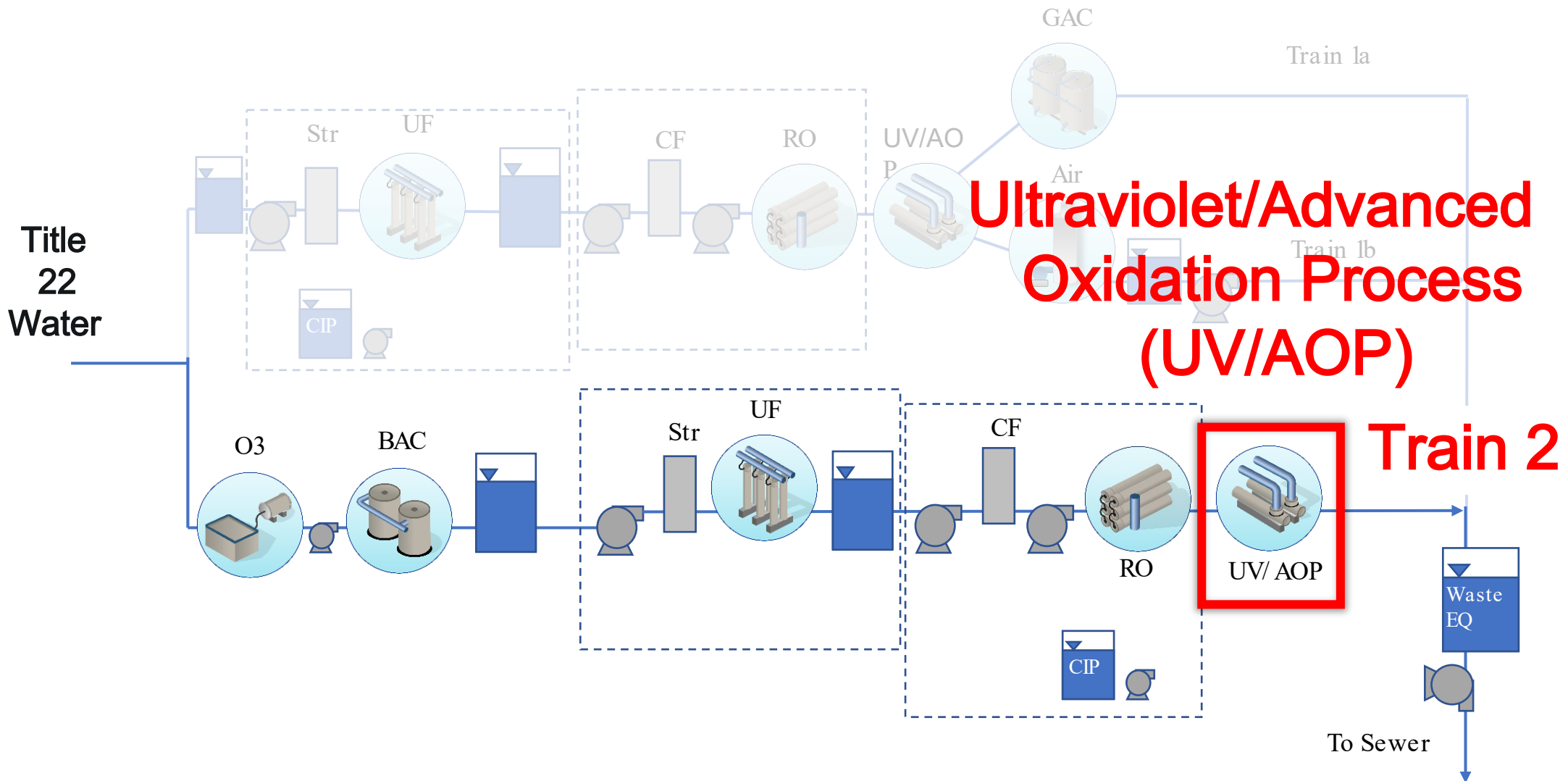

# Process Flow for Pilot

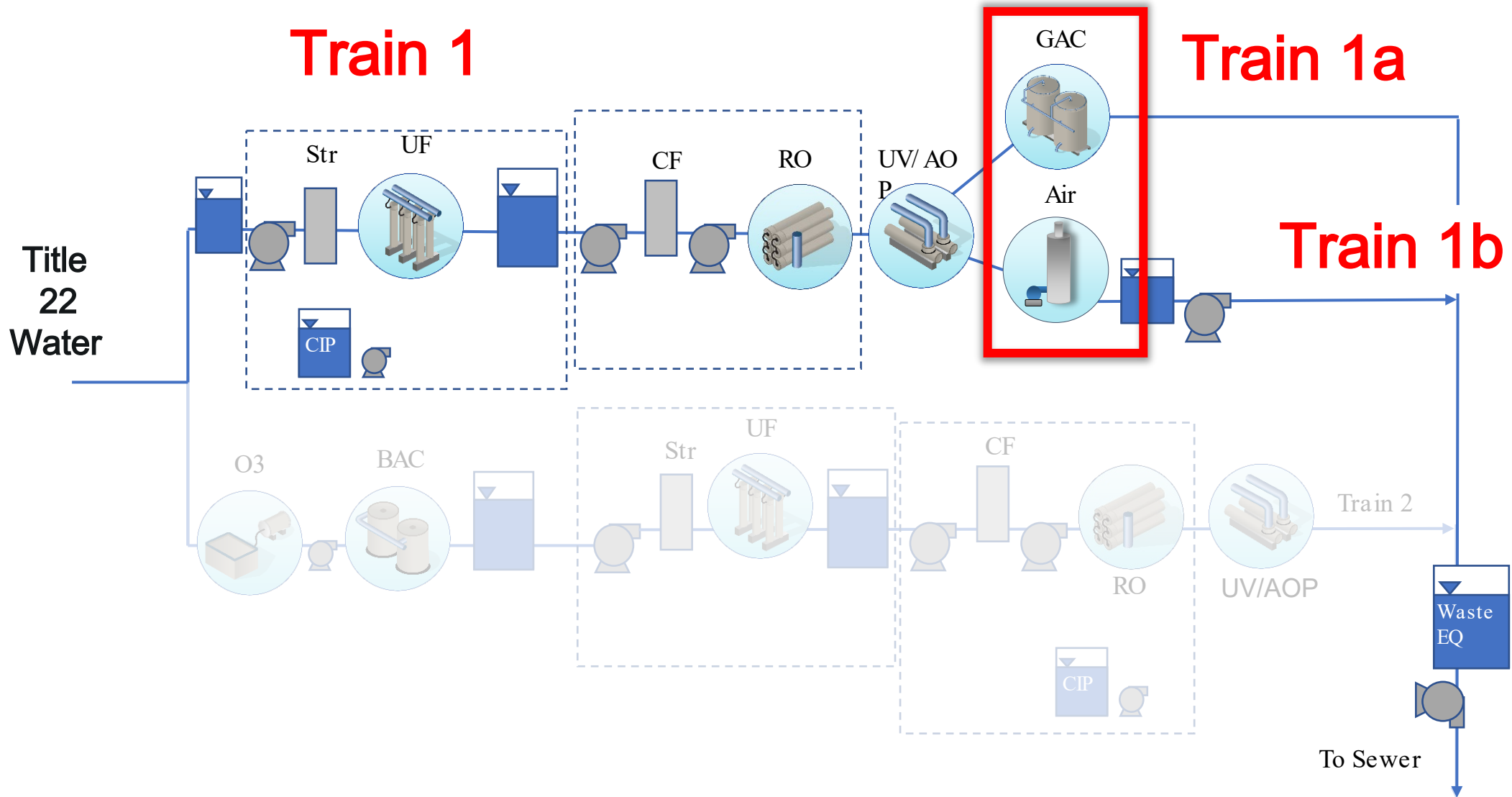

# Process Flow for Pilot

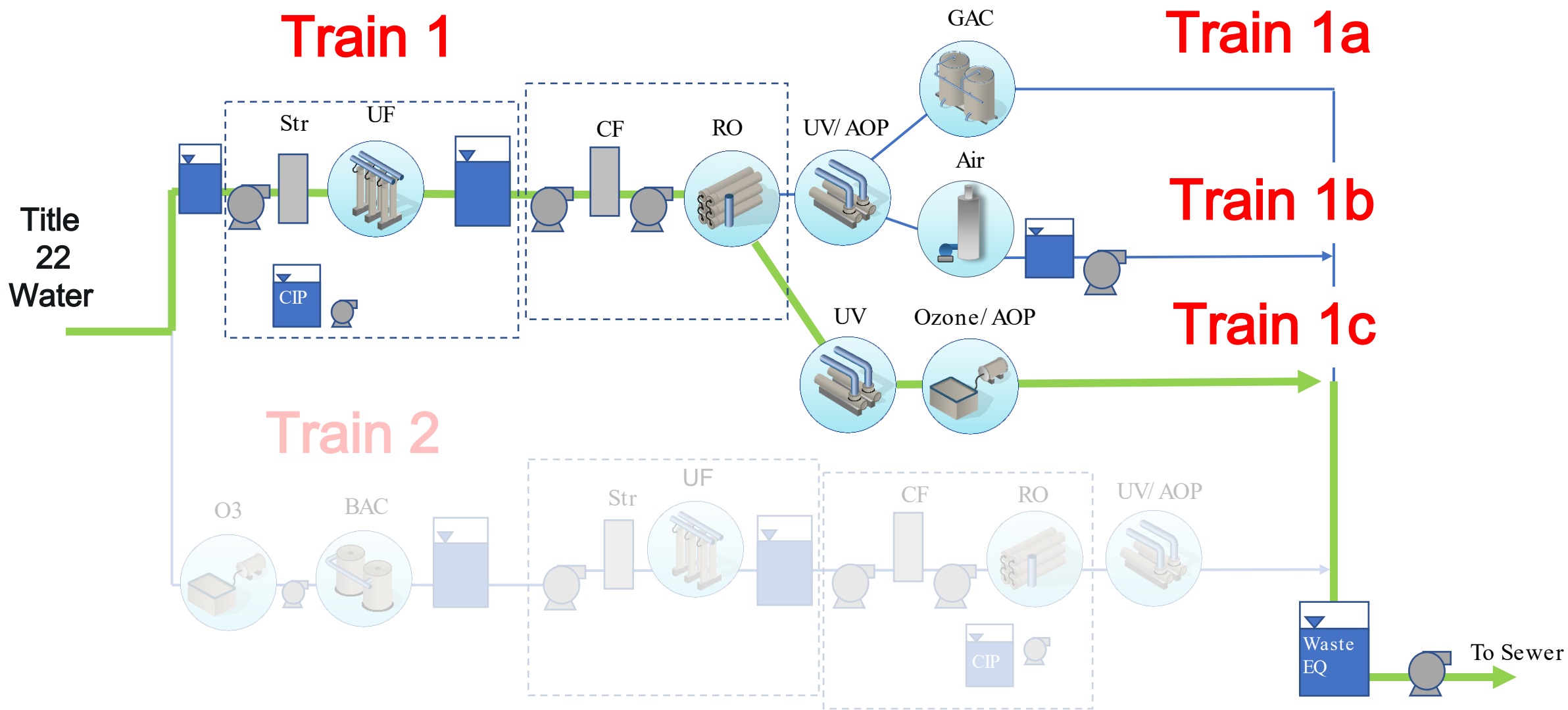



# DPR Pilot Setup



**O3/UV/GAC/AS**

**BAC**

**RO**

**UF**

# Processes Inside the Trailer



**Ozone Contactor**



**UV/AOP**



**GAC**



# Special Testing

- Bench-scale free chlorine disinfection testing
- Simulated distribution system testing
- Jar testing for post-treatment water quality
- Chemical spiking
- qPCR testing
- UV/ AOP challenge testing
- Post-RO ozone/ AOP challenge testing

# Chemical Spiking Approach

Focus on full treatment train rather than individual process

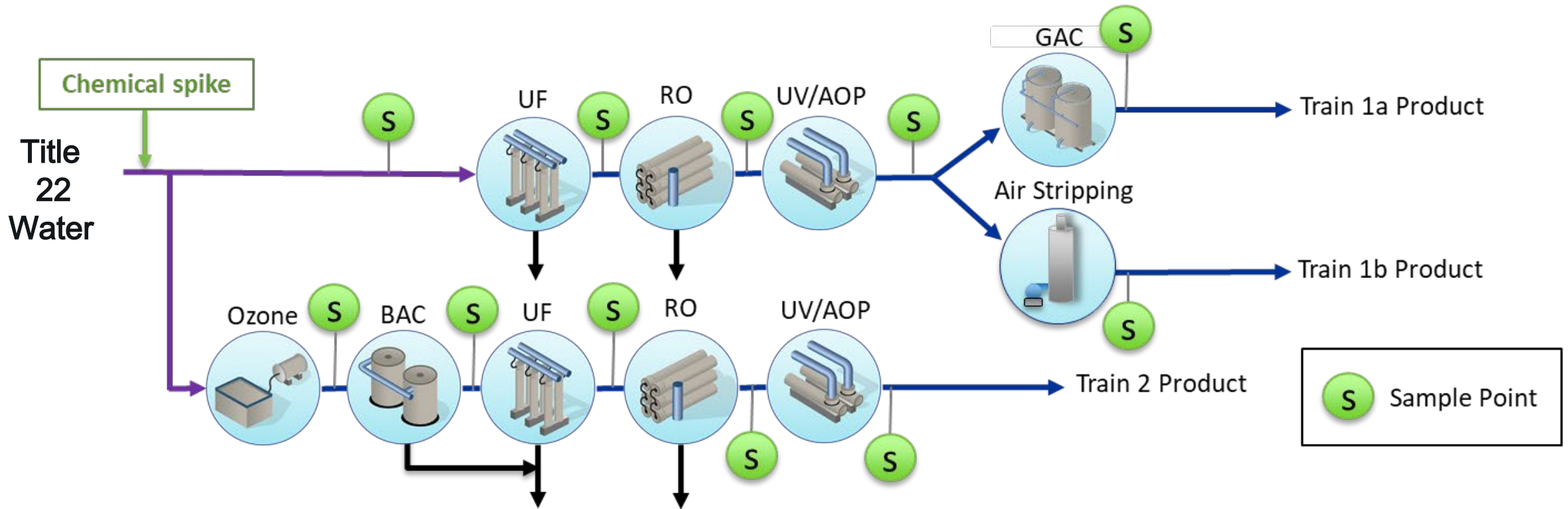



**Thank You!**



**LOS ANGELES COUNTY  
SANITATION DISTRICTS**  
*Converting Waste Into Resources*

# WaterReuse Legislative Update, LA Chapter

**Phillip Vander Klay**  
Legislative Liaison, LACSD

February 11, 2025



OUR SERVICE AREA

# Legislative Update

## Chaos in Washington

- Funding frozen, then unfrozen
- Water funding fine for now, EV funding in trouble
- Regulatory actions on hold – PFAS, etc
- Complete disregard for rule of law – no stability on what happens next
- Staff fired and agencies shut-down on a whim



# Legislative Update

## Sacramento Update

- \$2.5 billion in funding for LA fires response
- Executive Orders from Governor to speed rebuilding
- Bill introduction next week – wait and see
- Recycled water funding – bond & budget





# Legislative Outlook

## Action Items

- Get funding agreements executed quickly if possible
- Don't count on anything in the short term
- Earmarks still likely for FY 25 and FY 26
- We'll see how court cases and state legislative response develop



# WaterReuse LA Chapter Meeting

## February 11, 2025

### Division of Drinking Water Updates

Rebecca Christmann, Recycled Water Unit  
[rebecca.christmann@waterboards.ca.gov](mailto:rebecca.christmann@waterboards.ca.gov)



# Recycled Water Regulatory Updates

- [Regulations for Onsite Treatment and Reuse of Non-potable Water](#)
  - Public Notice of Proposed Rulemaking expected in late-March
- State Water Resources Control Board Meeting
  - Consideration of a Proposed Resolution adopting the prioritization of drinking water regulations development for calendar year 2025.
  - [Agenda Item 3](#)
  - [Draft Resolution](#)



# Chapter Trustee Updates

## WATEREUSE LA Chapter – February 11, 2025



Last Board of Trustees Meeting: February 10, 2025



### Strategic Planning Update

**Purpose:** To make recycled water work for communities in California

**Mission:** We convene the only community focused on delivering all forms of recycled water through leadership, education, and advocacy.

**Vision:** Recycled water is part of California's water future

### **Outcomes:**

- Our Members have knowledge needed to deliver recycled water
- Our Members develop relationships and grow business
- Our Members go through a streamlined regulatory process
- Our Members have funding for recycled water projects





# Chapter Trustee Updates

## WATEREUSE LA Chapter – February 11, 2025



Last Board of Trustees Meeting: February 10, 2025



### FY 24/25 Preliminary Budget

- Budget - \$1,050,572
- Revenue - \$1,173,459



### Preliminary FY2024 Financials

- Beginning Net Assets: \$1,095,391
- Ending Net Assets: \$886,059



### Leg/Reg Committee Guideline Revisions

- Revision Goal: To increase participation, engagement, and attendance
  - Number of Committee Members
  - Distribution Clarification
  - At Large Numbers and Attendance policy



### CalVal – Uniform LRV Guidance Manual Project

- Standardize DPR Permitting and Validation
- Funding from Members ~\$250k (includes participation from WRF)



# Chapter Trustee Updates

## WATEREUSE LA Chapter – February 11, 2025



**Last Board of Trustees Meeting:** February 10, 2025



### Proposed 2025 WRCA Special Projects

1. Water Loop Videos
  - Produce engaging video series to showcase the potential of waterreuse
2. Strategic Plan Implementation
  - Deliver the NEW strategic plan 1<sup>st</sup> quarter of 2025
3. Southern California Water Coalition Video
  - WRCA & SCWC to develop videos focused on improving perception of DPR
4. Regulation Guidebook
  - WRCA to develop regulatory guidebook for other states





# Chapter Trustee Updates

## WATEREUSE LA Chapter – February 11, 2025



Last Board of Trustees Meeting: February 10, 2025



### 2025 WaterReuse Symposium

- Tampa, FL – JW Marriot Tampa Water Street
- March 16<sup>th</sup> – 19<sup>th</sup> , 2025

Celebrating 40 Years!



### 2025 WaterReuse Annual Conference

- San Diego, CA - Town & Country Resort
- UPDATED: September 21<sup>st</sup> – 23<sup>rd</sup> , 2025





# LA Chapter Updates

- Communications Chair:  
*Oliver Slosser*  
[oslosser@lvmwd.com](mailto:oslosser@lvmwd.com)
- Ad Hoc Urban Irrigation Manual Update Co-Chairs:  
*Monica Sanchez, Erika Bensch, and Jesus Gonzalez*  
[monicasanchez@lacsds.org](mailto:monicasanchez@lacsds.org)
- Recycled Water User Manual Update Chair:  
*John Lockett*  
[primal.truth@gmail.com](mailto:primal.truth@gmail.com)
- Technical Topics Chair:  
*Alex Franchi and Dinaz Kureishy*  
[alex.franchi@aecom.com](mailto:alex.franchi@aecom.com)
- Volunteer Opportunity
  - Rising Professionals Committee Chair



# Member Agency Roundtable

- 40<sup>th</sup> WaterReuse Symposium
  - March 16-19, Tampa, FL
- CA WaterReuse Conference
  - September 21-23, San Diego, CA
- Needed - Chapter Meeting Hosts & Sponsors
- Needed - Technical Topic
  - Advanced Treatment Facility projects
  - PFAS
  - New regulations
  - Climate resiliency
  - New/emerging technologies.
  - Complying with IPR/DPR regulations
  - Digital application in Water Reuse
  - DPR related effort