

Declining Flow Issues

EL DORADO IRRIGATION DISTRICT

A solid green horizontal bar at the bottom of the slide.

EID GPCD

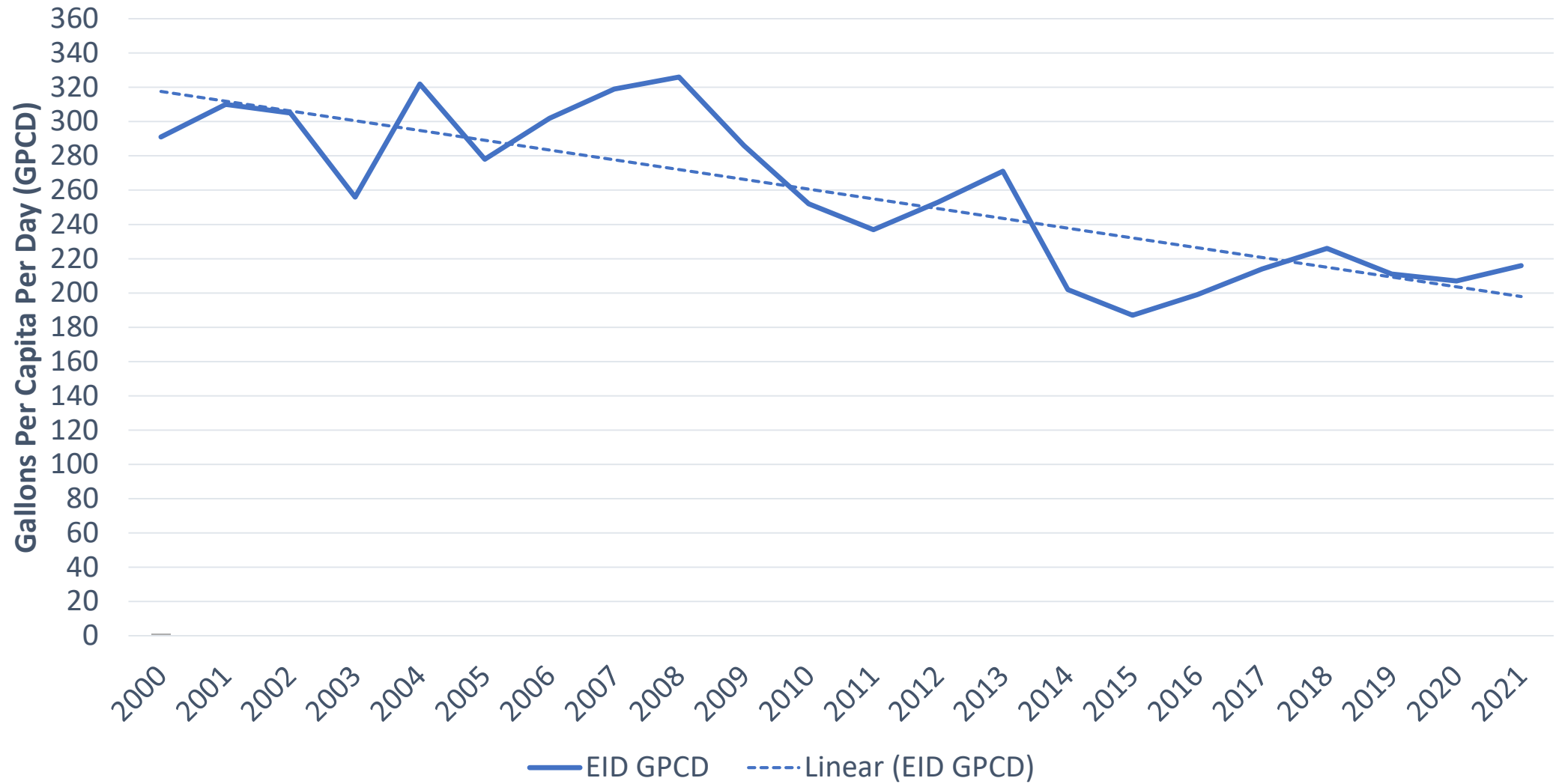

Wastewater Flows to Reclamation Facilities

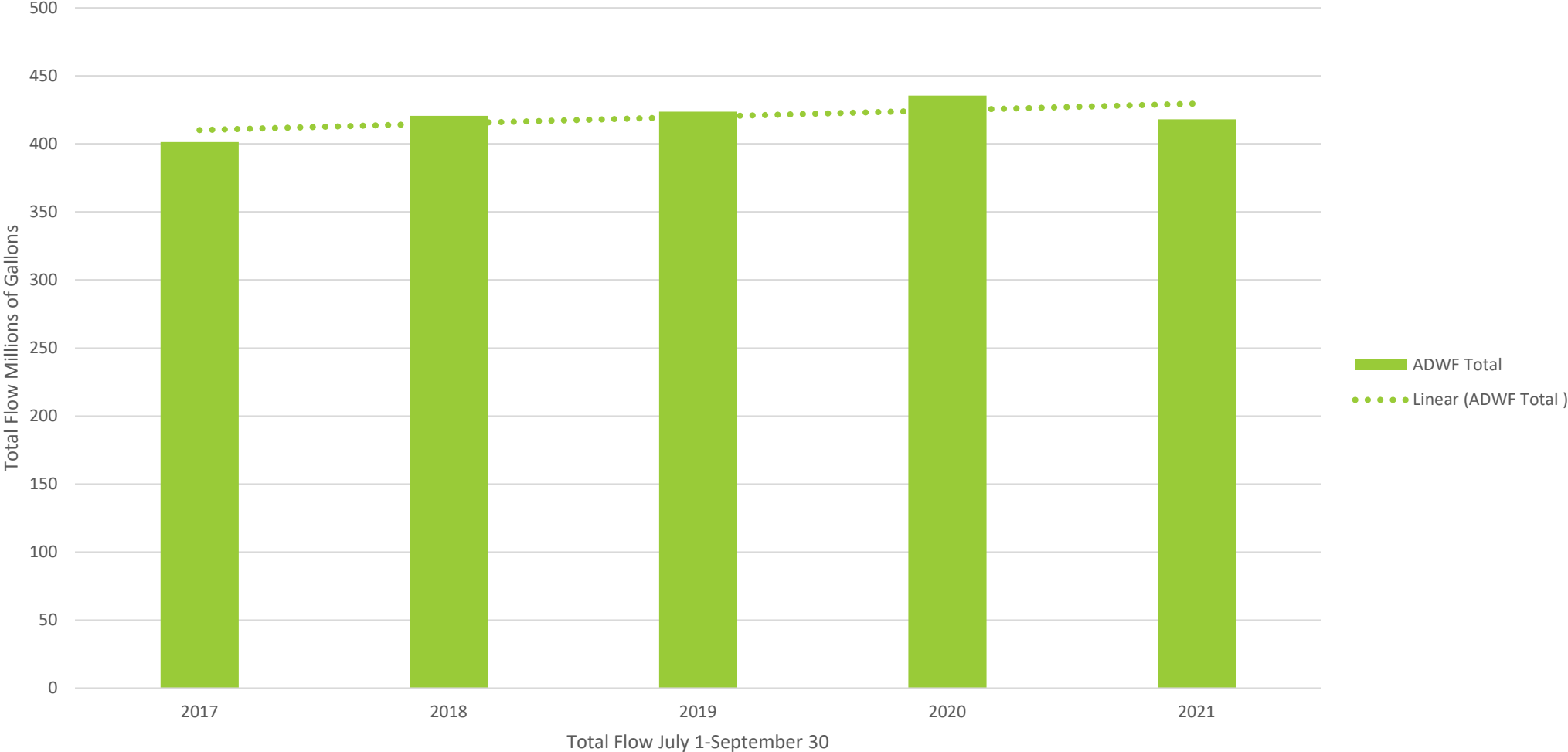

Recycled Water Usage

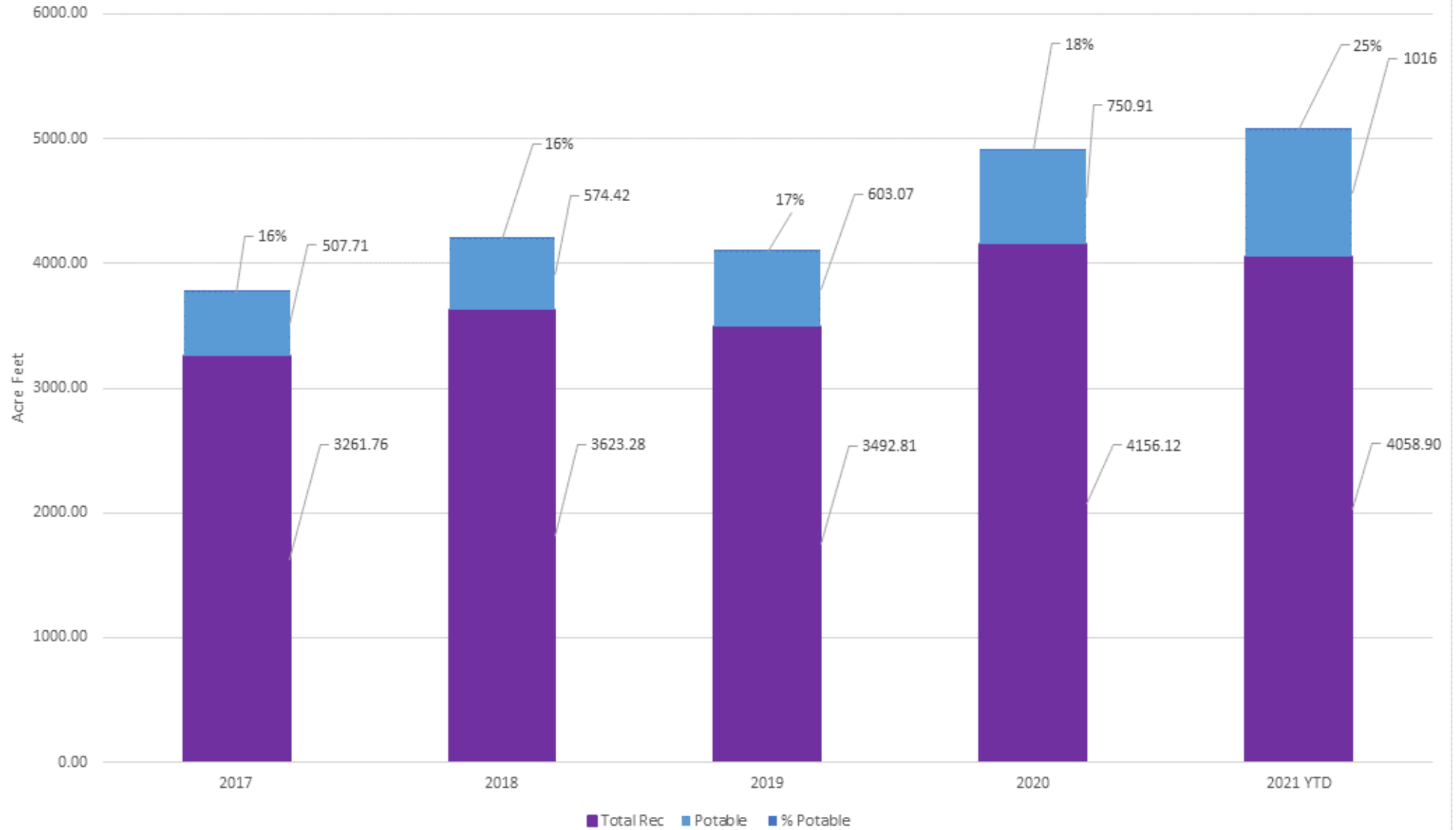

Odor & Corrosion Issues

Accelerated Corrosion of Collection System Assets



Odor Control Issues

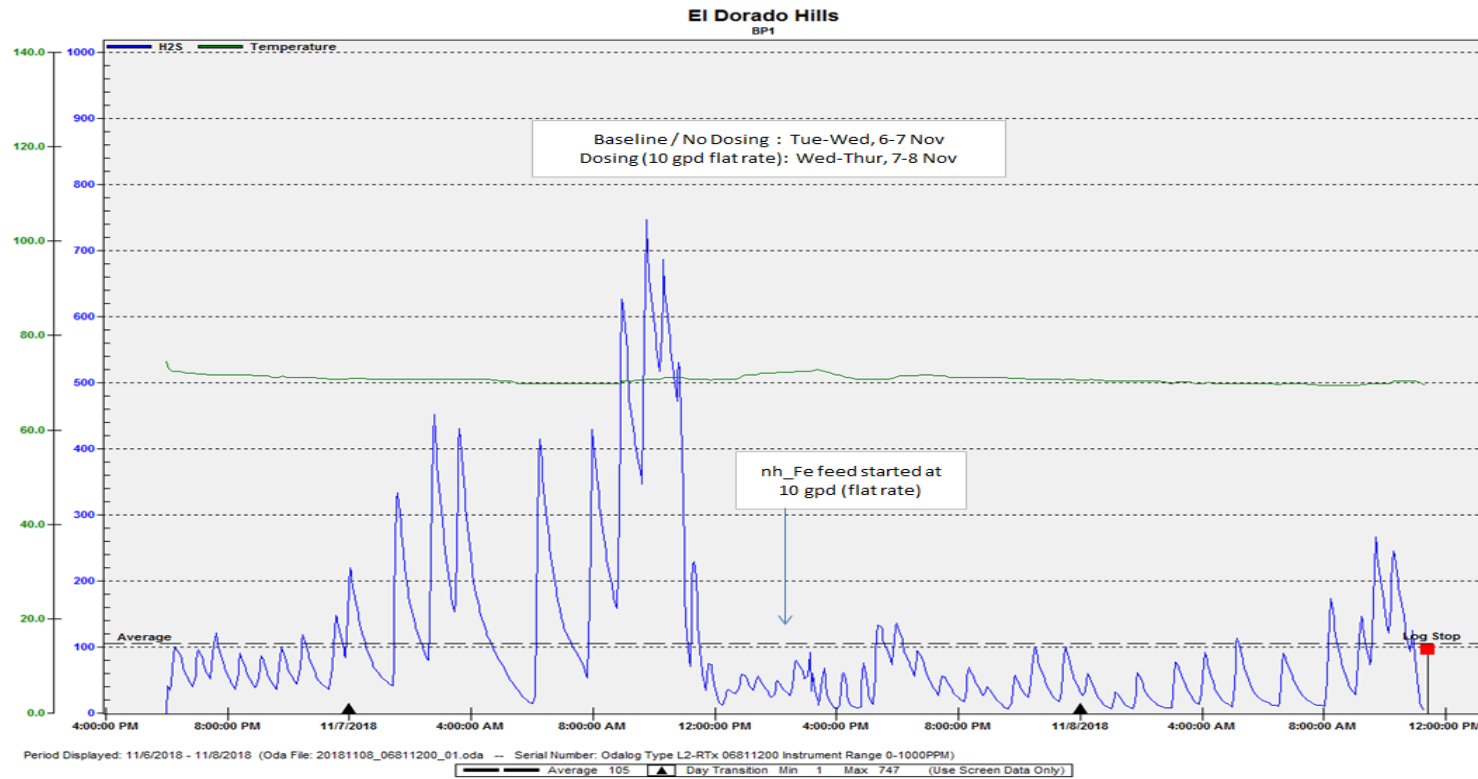

Additional Odor Control Strategies

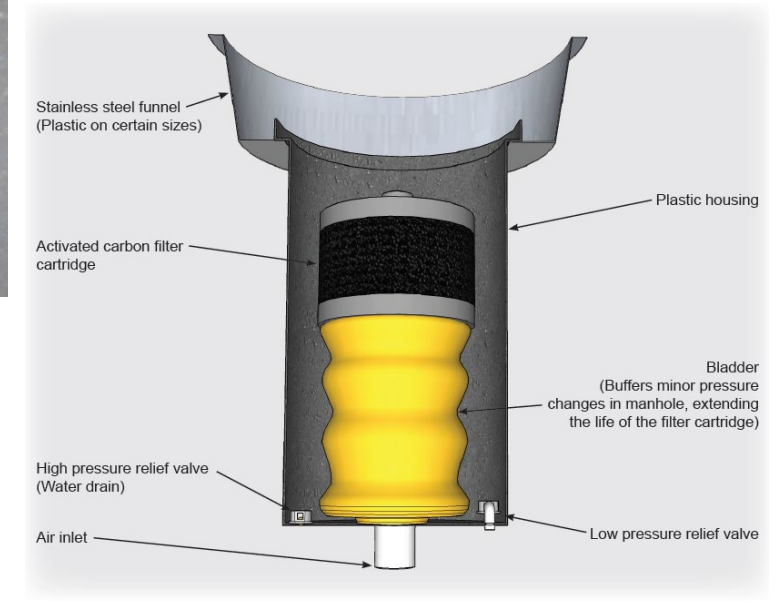

Budget Considerations

- \$250K/year for chemical Odor Control
- \$1M/ year supplemental water for recycled water program
- Unknown Cost for accelerated corrosion/deterioration of assets



Site	Gallons/Minute	Mililiters/Minute	Gallons/Hour	Gallons/Day	Gallons/Month
Summit 2	0.0007	3	0.042	1	30
Promontory Village 1	0.0083	32	0.500	12	360
Highland Hills	0.0042	16	0.250	6	180
Southpointe	0.0014	5	0.083	2	60
Summit View 1	0.0007	3	0.042	1	30
Town Center	0.0021	8	0.125	3	90